

HAF-601 (13-0087) Air Station

IMPORTANT: Read and follow all **INSTRUCTIONS** and **SAFETY PRECAUTIONS** before installing, operating or maintaining this equipment. Keep this manual for future reference.

SPECIFICATIONS

(1) Air Filter (Separator): 13-0041
 Air Inlet Thread 1/2" NPT(F)
 Air Outlet Thread 1/2" NPT(F)
 Air Flow Capacity 100 CFM
 Max. Temperature 150° F (65.6° C)
 Max. Inlet Pressure 150 PSIG
 Auto. Mechanical Drain Supplied
 Filter Element 5 Micron

(2) Coalescing Filter: HAF-505
 Air Inlet Thread 1/2" NPT(F)
 Air Outlet Thread 1/2" NPT(F)
 Air Flow Capacity 55 CFM
 Max. Inlet pressure 150 PSIG
 Max. Operating Pressure 150 PSIG
 Max. Temperature 150° F (65.6° C)
 Auto. Mechanical Drain Standard
 Filter Element 0.01 Micron

(3) Charcoal Filter: HAF-517
 Air Inlet Thread 1/2" NPT(F)
 Air Outlet Thread 1/2" NPT(F)
 Air Flow Capacity 75 CFM @
 100 PSI
 Max. Operating Pressure 150 PSIG
 (10.3 Bar)
 Max. Temperature 150° F (65.6° C)
 Manual Mechanical Drain Standard
 Pressure Differential
 Indicator Standard
 Aerosol Filter .003 ppm./wt.
 Particulate Filter 3.0 micron

(4) Flow-Thru Regulator: HAR-508
 Flow-Thru Ports 1/2" NPT(F)
 Regulated Ports 1/4" NPT(F)
 Air Flow Capacity, 28 CFM @
 60 PSI
 Regulated Ports With 100 PSI
 Inlet
 Max. Temperature 175° F (79.4° C)
 Max. Inlet Pressure 300 PSIG
 Regulator Range 0-125 PSIG

(5) Tool Air Regulator: HAR-507
 Air Inlet Port 3/8" NPT(F)
 Air Outlet Port 1/4" NPT(F)
 (3 ea.)
 Air Flow 60 CFM
 Max. Temperature 120° F (65.6° C)
 Max. Inlet Pressure 150 PSIG
 Regulator Range 0 to 125 PSIG

DESCRIPTION -- AIR STATION

All components in Figure 1 are included with the air station. This unit is designed to provide a source of clean, filtered air for the connection of both a DeVilbiss supplied air respirator and a paint spray gun. The unit removes dirt, pipe scale, water, oil,

Figure 1

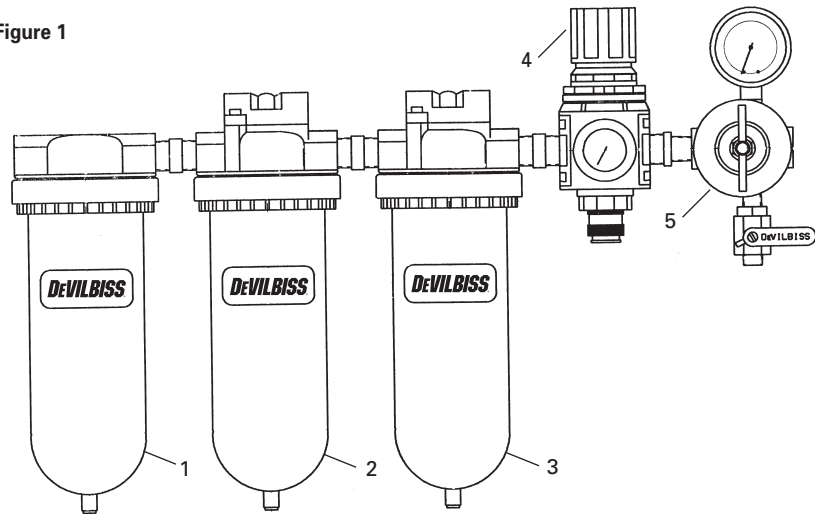

liquid aerosols, hydrocarbons and odors. One regulated port is provided for the connection of a DeVilbiss breathable air supply hose. A separate regulated port is fitted with a 1/4" NPS(M) hose connection for spraying applications.

BREATHING AIR REQUIREMENTS

Supplied breathing air, as defined by OSHA 29 CFR 1910.134i and NIOSH 42 CFR 84.141, MUST meet or exceed the following requirements for Type 1-Grade D breathable air, as defined in Compressed Gas Association (CGA-G7-1-1997):

Oxygen = 19.5-23.5% (Typical atmospheric levels)

Oil (condensed) = 5 mg/m (milligrams per cubic meter) maximum

Carbon Monoxide (CO) = 10 ppm (parts per million) max.

Carbon Dioxide (CO₂) = 1000 ppm (parts per million) max. (Typical atmospheric levels)

Odor = The presence of a pronounced odor should render the air as unsatisfactory

It is up to the employer to assure that the air compressor is properly maintained, that the air compressor intake is located in a clean contaminate free location and that the air compressor is drawing in typical atmospheric air, meeting all of the national and local requirements for breathing air.

This filter unit does not remove or filter Carbon Monoxide (CO). It is up to the employer to ensure that the level of CO does not exceed the maximum national or local allowed level. The recommended method to assure that the CO level is not exceeded is to install a carbon monoxide monitor and alarm.

This filter unit will only remove particulate matter, water, oil and odor. This filter unit will meet the particulate matter, oil and odor requirements of Type 1-Grade D Breathable Air and Compressed Breathing Air, CSA-Z180.1 when:

- The filter unit is connected to a compressed air source:
 - The compressor is properly maintained
 - The air compressor intake is located in a clean contaminate free location
 - The air compressor is drawing in typical atmospheric air, meeting all of the national and local requirements for breathing air
- The filters are properly maintained
- A properly operating CO monitor is installed



WARNING

Risk of explosion or fire. Improper use can cause personal injury.

- **This product is designed and intended for use in industrial compressed air systems only. Do not use for liquids or gasses other than air.**
- **Do not use where pressure or temperature can exceed rated operating conditions (see specifications).**
- **Regulated outlet pressure must never be set higher than the maximum operating pressure of the downstream air tool or equipment. An outlet pressure gauge should always be used.**

SAFETY PRECAUTIONS

This manual contains important information that all users must know and understand before using the equipment. This information relates to **USER SAFETY** and **PREVENTING EQUIPMENT PROBLEMS**.

To help you recognize this information, we use the following terms to draw your attention to certain equipment labels and portions of this manual. Please pay special attention to any label or information that is highlighted by one of these terms:



Important information to alert you to a situation that might cause serious injury if instructions are not followed.



Important information that tells how to prevent damage to equipment, or how to avoid a situation that might cause minor injury.



PROP 65 WARNING

WARNING: This product contains chemicals known to the State of California to cause cancer and birth defects or other reproductive harm.

Note

Information that you should pay special attention to.



Risk of illness or death. Carbon monoxide can cause nausea, fainting or death. Stop using if carbon monoxide is present. This unit does not remove carbon monoxide. A carbon monoxide monitor should be incorporated into your air supply line to warn of the presence of carbon monoxide.

on the separate components before using the system. Use only specified DeVilbiss parts.



Risk of equipment damage! Do not install your air station where it is subjected to sudden depressurization cycles exceeding 20 PSIG. Quick relieving air solenoid valves, typical in some spray booths, will eventually fail pressure gauges and filters.

receptacle. Prevent vinyl tubing from becoming kinked which would prevent free movement of liquids discharged from the automatic or manual drain.

8. An optional manual drain HAF-11) can be installed in place of the automatic drains.

INSTALLATION – MOUNTING BRACKETS

1. Use the mounting bracket as a template for locating the mounting holes.
2. Drill appropriate sized holes through booth wall as shown in Figure 2. Two 5/16" round head screws, nuts and lockwashers are supplied. If mounting into a solid or hollow wall, use anchors (not included).
3. Assemble mounting bracket to wall, positioning "L" bracket with top screw.
4. Tighten **bottom** screw firmly. Leave top screw partially loose so "L" bracket can slide up out of the way.
5. Place filter in the bracket, positioning between curved saddle ears. See Figure 1 on Page 1.
6. Slide "L" bracket down against top of filter, then firmly tighten the top screw.



Risk of injury. Do not place unit in service without metal bowl guard installed. Filter units are sold only with metal bowl guards. To minimize the danger of flying fragments in the event of plastic bowl failure, guard must not be removed. If the unit is in service without the metal bowl guard installed, manufacturer's warranties are void and the manufacturer assumes no responsibility for any resulting loss. If unit has been in service and does not have a metal bowl guard, order one and install before placing back in service.

To minimize sudden depressurization effect, replace the existing solenoid with a "slow closing solenoid valve". (One source: Automatic Switch Co). Or, install an air adjusting valve at the existing solenoid valve outlet.

For ease of installation and maintenance, attach the assembled air station to the main air line using a pipe union, (not included).

1. Be sure to read all **Warnings** and **Cautions** in this manual and component manuals on the unit before installation or using this equipment.
2. Install air station system as close as possible to the point where the air is being used. Use enclosed mounting bracket to support Air Station.
3. Install main shut-off valve (supplied by user) upstream of air drying system to allow maintenance to the unit.
4. Install unit with air flow through filter in direction of arrow on top of filters.
5. Minimum 3/4" NPT piping is recommended. Avoid using fittings, couplings, etc. that restrict air flow.
6. **Maximum inlet pressure and operating temperature is: 150 PSIG and 120° F (48.9 C)**
7. Three 6' lengths of vinyl tubing are shipped loose with the system. Slide over drains which protrude from bottom of the filters. Place the other end of vinyl tubing into appropriate



Certain compressor oils, cleaning agents and solvents may attack the plastic and rubber components used in the construction of this product. This product should not be used in conjunction with or in the vicinity of these materials. Read and follow material labels carefully. Please consult DeVilbiss if in doubt.

INSTALLATION – AIR STATION



Risk of explosion and injury. Release all air pressure from system before servicing system. Be sure to read and understand all Service Bulletins

Figure 2 – Mounting Bracket

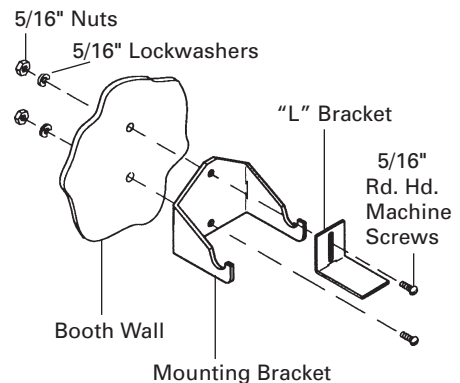

OPERATION – AIR STATION

After the system is installed and ready to use:

1. Attach breathable air hose to connection on flow-through regulator.
2. Attach spray air hose to outlet ball valve on spray gun regulator.
3. Open main shut-off valve upstream of system.
4. Attach breathable air hose to supplied air respirator. Adjust pressure on flow-through regulator to 60 PSIG (flowing). The pressure should never be allowed to drop below 50 PSI in a flowing condition.
5. Open ball valve to supply air to spray gun or tool being used. With air flowing, adjust air pressure to desired setting.

Figure 3 – 13-0041

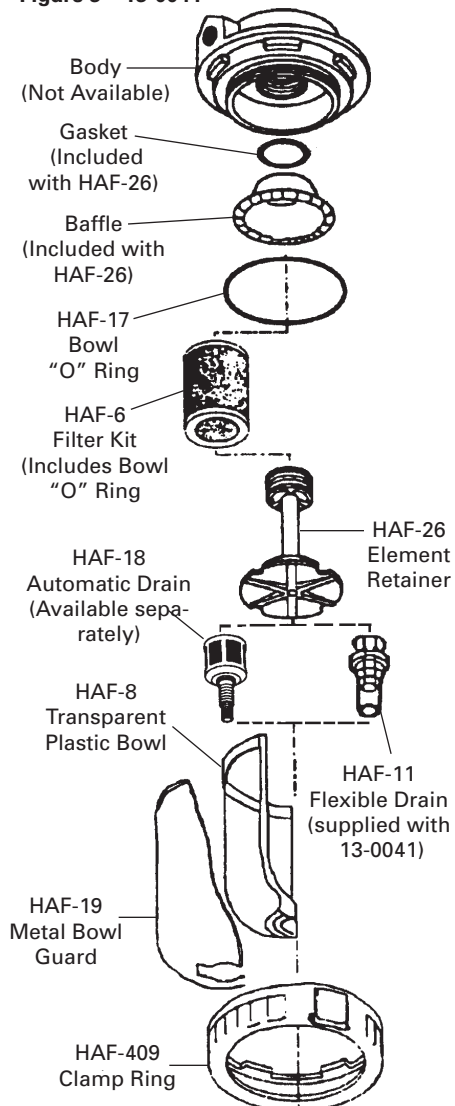

MAINTENANCE – WATER SEPARATOR FILTER 13-0041

1. Before performing maintenance on unit, close any main shut-off valve located upstream of filter. Bleed off residual air in unit.
2. To open filter, press button located on clamp ring and rotate ring either clockwise or counterclockwise while pulling down on ring. The metal bowl guard and plastic bowl can then be removed from the filter body.
3. Remove the filter element by loosening counterclockwise. Clean or replace the filter element. Frequency of element replacement will depend upon air quality, air usage and condition of the air piping. It is recommended to change the element every six months.
4. Inspect "O" ring for damage. Replace if necessary.
5. Inspect plastic bowl for signs of damage such as cracks, crazing or deterioration. Replace if necessary.

MAINTENANCE – COALESCING FILTER HAF-505

1. Before performing maintenance on unit, close any main shut-off valve located upstream of filter. Bleed off residual air in unit.
2. To open filter, press button located on clamp ring and rotate ring either clockwise or counterclockwise while pulling down on ring. The metal bowl guard and plastic bowl can then be removed from the filter body.
3. Remove the filter element by loosening counterclockwise. Clean or replace the filter element. Frequency of element replacement will depend upon air quality, air usage and condition of the air piping. It is recommended to check the element change indicator daily and replace element when indicator turns red.
4. Inspect "O" ring for damage. Replace if necessary.
5. Inspect plastic bowl for signs of damage such as cracks, crazing or deterioration. Replace if necessary.

Note

6. The filter change indicator only operates when air is flowing. It will always be green when there is no air flow.

Figure 4 – HAF-505

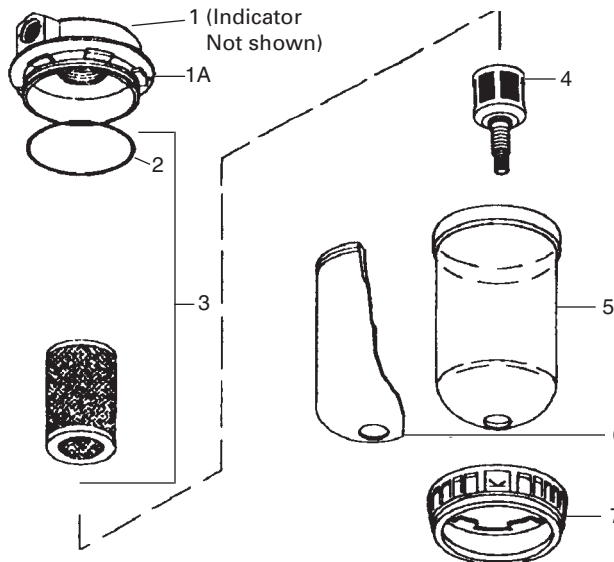

HAF-505 Parts List

Ref. No.	Replacement Part No.	Description	Ind. Parts Req.
1	HAF-404	Filter Change Ind. (Not shown)	1
1A		Body	1
2		"O" Ring	1
3	HAF-28	Filter & "O" Ring Kit	1
4	HAF-18	Automatic Drain	1
5	HAF-8	Plastic Bowl	1
6	HAF-19	Metal Bowl Guard	1
7	HAF-409	Clamp Ring	1

**MAINTENANCE – HAF-517
CHARCOAL FILTER**

1. Before performing maintenance on unit, close any main shut-off valve located upstream of filter. Bleed off residual air in unit.
2. To open filter, press button located on clamp ring and rotate ring either clockwise or counterclockwise while pulling down on ring. The metal bowl guard and plastic bowl can then be removed from the filter body.
3. Remove the filter element by loosening counterclockwise. Clean or replace the filter element. Replace the charcoal element when it no longer removes oil vapor odors or when the red indicator is visible.
4. Inspect "O" ring for damage. Replace if necessary.
5. Inspect plastic bowl for signs of damage such as cracks, crazing or deterioration. Replace if necessary.

HAF-517 Parts List

Ref. No.	Replace. Part No.	Description	Ind. Parts Req.
1	HAF-404	Filter Change Ind. (Not shown)	1
1A	---	Body	1
2	---	"O" Ring	1
3	HAF-36	Filter Element and "O" ring Kit	1
4	HAF-11	Manual Drain	1
5	HAF-8	Plastic Bowl	1
6	HAF-19	Metal Bowl Guard	1
7	HAF-409	Clamp Ring	1

Figure 5 – HAF-517

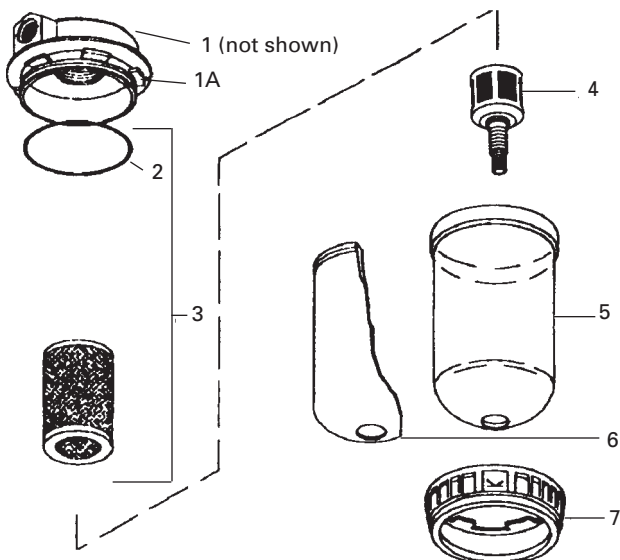

**MAINTENANCE – AIR PRESSURE
REGULATOR HAR-507**

1. Occasionally remove bottom plug (7) and clean valve seat (11) and body. Clean parts with denatured alcohol, wipe off seat and blow out body with compressed air.
2. To disassemble regulator, remove screws, bonnet, spring and spring button. Diaphragm assembly can now be removed.
3. Check all O-rings for signs of damage. Replace if necessary.
4. Reassemble parts. Insert stem of valve through hole in regulator body. Install spring and o-rings. Screw bottom plug into body.

Note

Erratic operation or loss of regulation is usually due to dirt in the valve area and cleaning is necessary. If cleaning does not correct the problem, replace the items included in Repair Kit KK-4977. If unit leaks air at **A**, install Repair Kit KK-4977.

Figure 6 – HAR-507

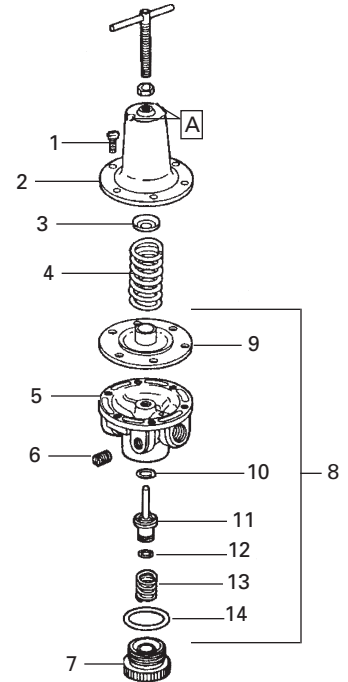

PARTS LIST – Model HAR-507 Regulator Assy.

Ref. No.	Replace. Part No.	Description	Ind. Parts Req.
1	—	#10-32x9/16 Fillister Hd. Screw	6
2	HAR-14	Cover	1
3	—	Spring Button	1
4	—	Diaphragm Spring	1
5	—	Body	1
6	—	Pipe Plug 1/4" NPT(M)	1
7	—	Bottom Plug	1
8	KK-4977	Repair Kit (includes Items 9 thru 14)	1
9	—	Diaphragm Assy.	1
10	—	O-Ring	1
11	—	Valve	1
12	—	O-Ring	1
13	—	Spring	1
14	—	O-Ring	1

**MAINTENANCE –
FLOW-THRU REGULATOR**

CAUTION

Do not submerge regulator or components in solvent or use solvent to clean regulator parts. Damage may occur to regulator and components. Use a cloth dampened in warm, soapy water to clean exterior of regulator.

Note

This unit may be serviced without removing the unit from the compressed air line.

1. Frequency of servicing depends largely on the condition of the compressed air system and the degree of contamination in the system.
2. Before attempting to service this product in-line, depressurize both the upstream and downstream sides of regulator.
3. Remove the bottom plug, valve spring and valve assembly. Inspect all seals and components for damage and replace as required. Clean seals and components with mild detergent and water. Use a clean, dry cloth to wipe any contamination from valve seal inside the body. Lubricate the valve stem and lower valve O-ring seal with a light coat of MAGNALUBE-G or similar lubricant. Reassemble. Bottom plug torque should not exceed 25 in./lbs. (2.8 N-m).
4. To replace main spring or diaphragm, turn adjusting knob counterclockwise to remove all spring force, then remove bonnet. Remove the adjusting screw assembly, main spring, slip ring and diaphragm assembly. Inspect the diaphragm and the relief seat for damage and contamination. Replace diaphragm assembly if necessary. Clean the relief seat with a soft dry cloth. Reassemble in reverse order making sure the slip ring is properly positioned on top of the diaphragm. Bonnet torque should not exceed 120 in./lbs. (13.6 N-m).

* KK-5045 Diaphragm Repair Kit

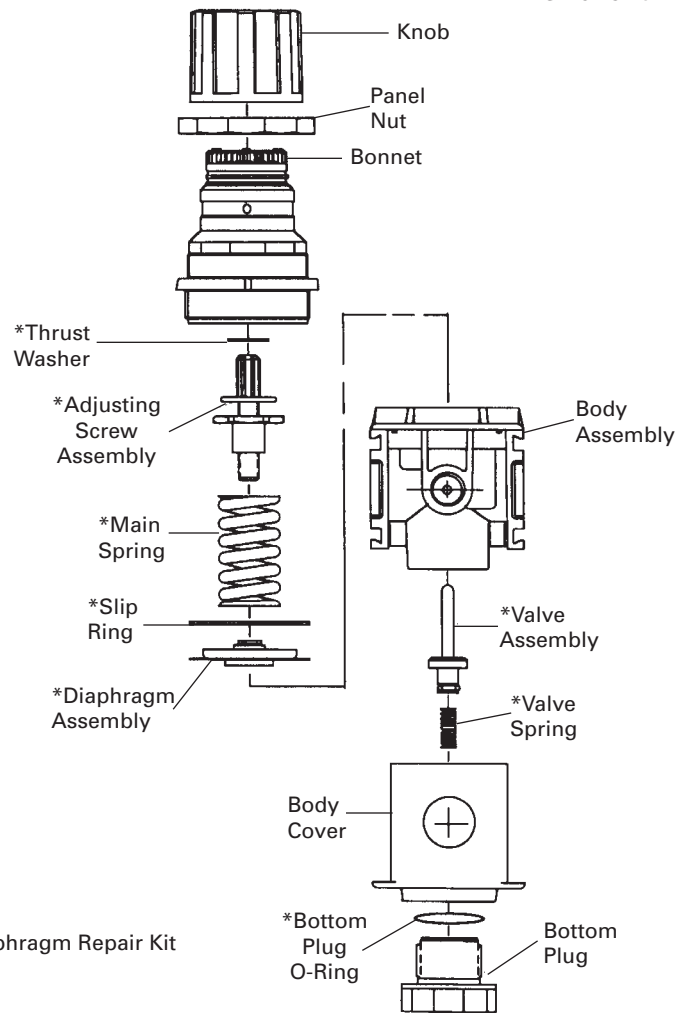

Figure 7 – HAR-508 Regulator

5. Before returning unit to service, ensure that all seals have been properly reinstalled or replaced and components requiring torque values have been properly set.
6. If regulated pressure begins to creep (an uncontrolled rise in regulated pressure), it will most likely be caused by contamination on the valve seat.
7. If the unit leaks from the vent holes in the bonnet, it may be caused by contamination, deterioration or damage to the valve seat or diaphragm relief seat. Replace any damaged or worn components.

HAF-18 Automatic Drain

Note

The automatic drain includes a float. If water gets into the float, the automatic drain may not function properly. Under normal conditions, water will not enter the float. However, water can get in the float if the filter bowl is washed with the drain installed or if air line contamination causes the drain mechanism to stick.

You can confirm the automatic drain is not operating if the water level in the plastic bowl is higher than the top of the automatic drain.

To remove water from the float, follow these instructions. Be careful not to lose or damage any internal parts of the automatic drain (replacement parts are not available - complete drain replacement will be necessary).

1. Remove automatic drain from plastic bowl by loosening plastic retaining nut. Keep retaining nut and O-ring for reassembly later.
2. Using a knife edge, carefully pry apart the float cover and bottom piece (See Figure 8).

Pry apart with knife edge.

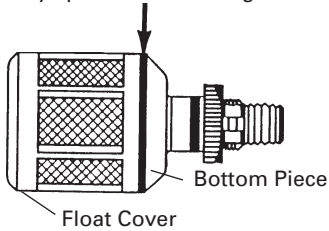

Figure 8

3. Slide flat off flat guide (See Figure 9).

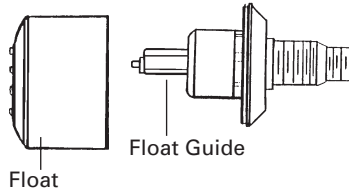

Figure 9

4. Using a knife edge, carefully pry off flat cap (See Figure 10).

Pry apart with knife edge.

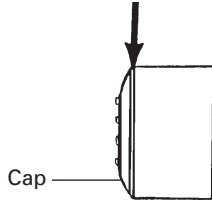

Figure 10

5. Clean inside of flat. Remove all traces of water or dirt.

6. Insure rubber seal is in place in the center of the flat stem (See Figure 11). If the seal comes out, press it back in place in the recess of the stem.

7. Replace the float cap (again, be certain the rubber seal, Figure 11, is in place).
(Inside view of float)

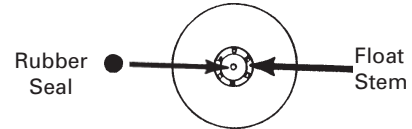
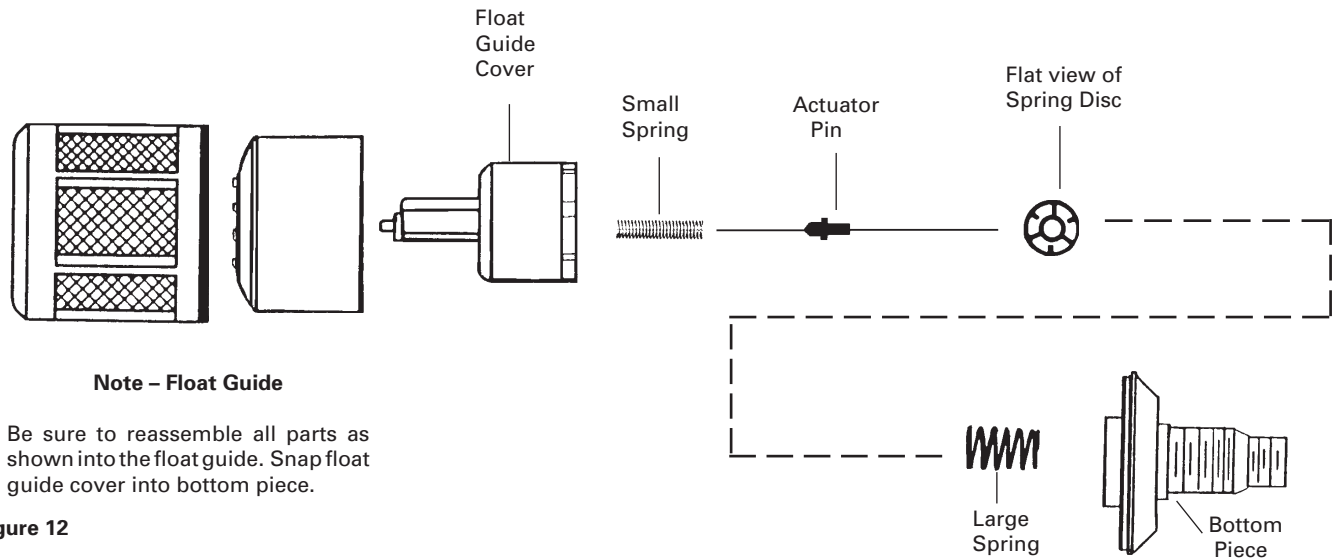

Figure 11

8. Slide float over float guide.
9. Snap float cover onto bottom piece.
10. Install automatic drain into bowl. Be sure O-ring is in place (between the drain and bowl). Tighten the plastic retaining nut firmly by hand.
11. Monitor the automatic drain for proper operation. If it fails to operate properly, replace with a new unit.

Note

If the Float Guide inadvertently came apart, refer to Figure 12 and instructions.



Note - Float Guide

Be sure to reassemble all parts as shown into the float guide. Snap float guide cover into bottom piece.

Figure 12

CLEANAIR™ AIR PIPING RECOMMENDATIONS

The plumbing of your shop air lines is very important. Correct installation is necessary for the proper performance of your equipment—for an uncontaminated air supply and for sufficient pressure to your breathing apparatus and spray gun.

Correct air line piping is so important that this one factor alone can reduce contaminants in your air supply up to 75%. Reducing contaminants to the filter also reduces the frequency of filter replacement, maintenance, and of course reduces the risk of contaminants to the painter and paint supply.

Even the size of the pipe is critical. Using pipe that is too small in diameter can cause a pressure drop.

Example: If an air compressor delivers 100 psi through a 100' pipe 1/2" in diameter, there's greater pressure drop than if a 3/4" diameter pipe were used. The chart on the back page provides recommended piping sizes.

AIR LINE PIPING GUIDE

- ① After leaving the air compressor, the air line should go straight up as high as possible. This helps prevent any water from leaving the compressor and travelling through the pipe.
- ② Horizontal pipes should slope back towards the compressor at least 4" per 50'. As warm air leaves the compressor, it cools and thereby water vapor condenses as it travels through the pipe. This water, a problem in itself, also can cause scaling and rust inside the piping. The backward sloping of the pipe helps drain these contaminants back toward the compressor drain which should be drained daily.
- ③ A take off should come from the top of the main air supply line at each air drop. This reduces the risk of water and other contaminants from traveling down the drop into the water separator.
- ④ Pipe diameter must be of sufficient size for the volume of air being passed as well as the length of pipe used. This will minimize pressure drop. See chart.

- ⑤ First air drop should be at least 25' from the compressor, although 50' is optimum. This allows the compressed air to cool so any condensation can occur before it gets to the air filter.
- ⑥ Shut-off valves are installed before the point of use filter. This allows air to be shut off for filter maintenance.
- ⑦ Point-of-use filter - Strongly recommended for eliminating any remaining contaminants. The DeVilbiss CleanAir type air control units are most effective in providing a truly contaminant-free air supply.
- ⑧ Drain valve - The daily draining of the system at each outlet disposes of the contaminants that build up in the air supply.
- ⑨ Drain the compressor trap daily if equipped with a manual drain.

Proper maintenance of the air compressor can reduce airborne contaminants such as particles and oils, and reduce heat and operating cost. Check air filters, oil level and perform regular maintenance per operators manuals.

MINIMUM PIPE SIZE RECOMMENDATIONS CHART

Compressor Size	Compressor Capacity	Main Air Line	Min. Pipe Diameter
1-1/2 & 2 HP	6 to 9 CFM	Over 50 ft.	3/4"
3 & 5 HP	12 to 20 CFM	Up to 200 ft. Over 200 ft.	3/4" 1"
5 to 10 HP	20 to 40 CFM	Up to 100 ft. 100 to 200 ft. Over 200 ft.	3/4" 1" 1-1/4"
10 to 15 HP	40 to 60 CFM	Up to 100 ft. 100 to 200 ft. Over 200 ft.	1" 1-1/4" 1-1/2"

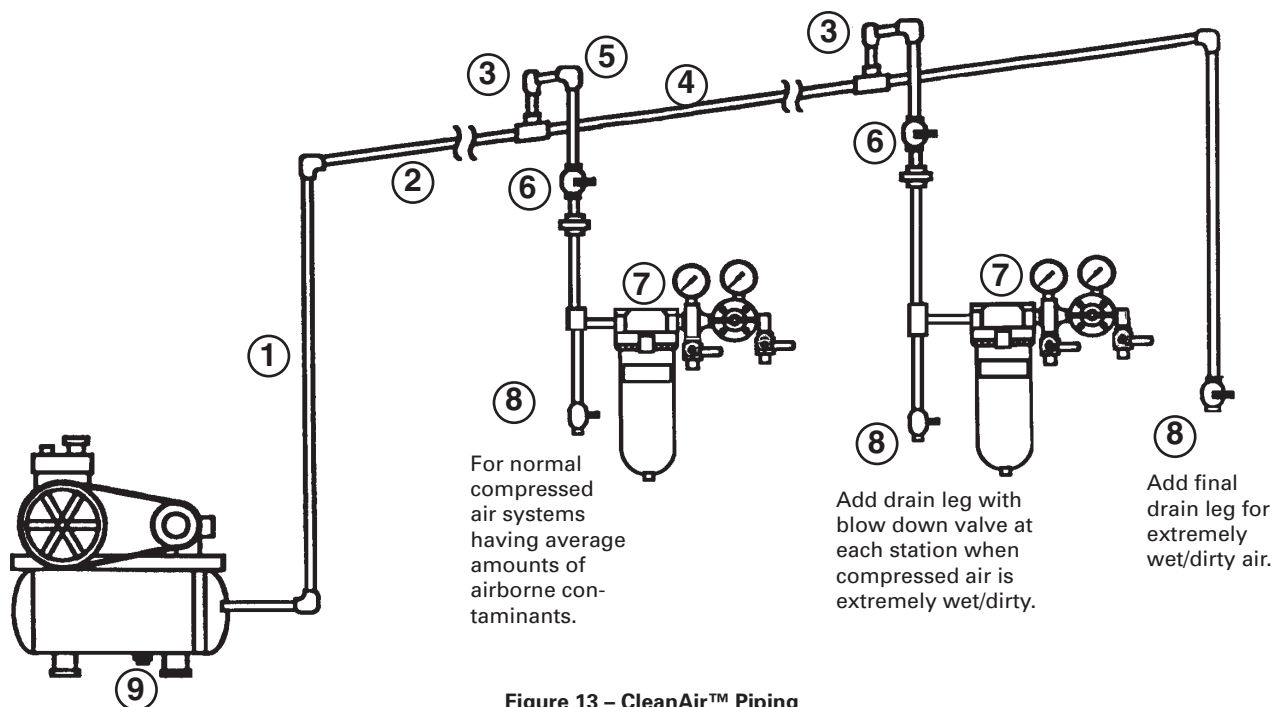

Figure 13 – CleanAir™ Piping

ACCESSORIES



WARRANTY

This product is covered by DeVilbiss's 1 Year Limited Warranty. Your DeVilbiss Air Station is warranted to be free of defects in materials and workmanship for a period of one year from date of original purchase. This warranty does not cover failures resulting from abuse, improper maintenance, misuse, or normal wear. If found to be defective during the warranty period, DeVilbiss will at it's own option, either repair or replace the product. THERE IS NO OTHER EXPRESS WARRANTY. IMPLIED WARRANTIES, INCLUDING THOSE OF MERCHANTABILITY AND FITNESS FOR A PARTICULAR PURPOSE ARE LIMITED TO A TWELVE MONTHS FROM PURCHASE AND TO THE EXTENT PERMITTED BY LAW ANY AND ALL IMPLIED WARRANTIES ARE EXCLUDED. THIS IS THE EXCLUSIVE REMEDY, AND LIABILITY OR CONSEQUENTIAL AND INCIDENTAL DAMAGES UNDER ANY AND ALL WARRANTIES IS EXCLUDED TO THE EXTENT EXCLUSION IS PERMITTED BY LAW. Some states do not allow limitations on how long an implied warranty lasts, or the limitations or exclusion of consequential or incidental damages, so the above limitations or exclusions may not apply to you.

DeVilbiss Sales and Service: www.devilbiss.com

DeVilbiss

DeVilbiss has authorized distributors throughout the world. For technical assistance or the distributor nearest you, see listing below.

U.S.A./Canada Customer Service Office:

195 Internationale Blvd., Glendale Heights, IL 60139
Toll-Free Telephone: 1-800-992-4657 (U.S.A. and Canada only)
Toll-Free Fax: 1-888-246-5732

DeVilbiss Automotive Refinishing

DeVilbiss has authorized distributors throughout the world. For equipment, parts and service, check the Yellow Pages under "Automotive Body Shop Equipment and Supplies." For technical assistance, see listing below.

U.S.A./Canada Customer Service Office:

11360 S. Airfield Road, Swanton, OH 43558
Toll-Free Telephone: 1-800-445-3988 (U.S.A. and Canada only)
Toll-Free Fax: 1-800-445-6643

