



# Binks STEADI-GRIP "SG-2" 2 QT. PRESSURE CUPS

**Model No. 80-350 (Standard)**  
**Model No. 80-351\* (with Agitator)**

## INTRODUCTION

Binks Steadi-Grip "SG-2" Pressure Cup is ideal for component spraying and industrial applications where small batch production spraying is required. The 2 qt. capacity is sufficient to complete large spray jobs without refilling the cup. Its lightweight and rugged construction is excellent for portability allowing the operator to make fluid and air control adjustments quickly and efficiently at the spray station.

The internal construction is designed for waterborne and solvent base materials.

Other features include:

- Stainless steel pick-up tube, fluid fittings and removable plastic liner makes it corrosion resistant.
- "Wide-mouth" opening allows easy cleaning, plastic liner removal and quick color change.
- Positive grip carrying handle for operator comfort.
- Wide stainless steel base for stability and corrosion resistance.
- 0-15 psig fluid pressure range.
- Optional 0-40 psig pressure kit available for high viscosity fluids.
- Fluid agitator on model 80-351 for metallics and paints requiring continuous agitation

## SPECIFICATIONS

MAX. WORKING PRESSURE	.50 psig	3.5 KG/cm <sup>2</sup>
OVERALL HEIGHT		
WITH AUXILIARY HANDLE	.16 9/16 in.	42.06 cm
WITHOUT AUXILIARY HANDLE	.11 3/4 in.	29.85 cm
BASE DIAMETER		
DIA. ACROSS CLOSED CLAMPS	.8 1/16 in.	20.47 cm
DIA. ACROSS OPEN CLAMPS	.8 1/16 in.	20.47 cm
AIR INLET & OUTLET CONNECTION SIZE		
FLUID OUTLET CONNECTION SIZE	.3/8 NPS (m)	--
FLUID CAPACITY	.2 Qts. (U.S.)	1.9 Liters
WEIGHT		
STANDARD UNIT.	.4 lb.13oz.	2.18 kg.
UNIT WITH AGITATOR	.5 lb.6oz.	2.44 kg.

## **⚠ WARNING**

All air and fluid pressure in the system must be relieved before servicing the cup and before cup is filled or cleaned. Attempting to service the cup while pressurized could result in damage to components or personal injury.



MODEL NO. 80-350 (Standard)



MODEL NO. 80-351\* (with Agitator)

\*Available from Industrial Finishing distributors only.

Replaces  
Part Sheet  
2658R-3

Part  
Sheet  
77-2658R-4

## SETUP AND OPERATION

Refer to "TYPICAL INSTALLATION" drawing below

Set up the Steadi-Grip "SG2" with the CONVENTIONAL or HVLP gun along with at least 5 ft. of air and fluid hose.

Attach air hose from extractor to air inlet on handle of steady-grip assembly. Pour paint into canister with liner. Re-attach lid to canister and firmly tighten four knobs over canister lid. Set air pressure from air regulator mounted on extractor and fluid pressure by adjusting fluid pressure adjustment knob on cup handle.

### ⚠ WARNING

Chlorinated solvents and aluminum are incompatible and will cause an adverse chemical reaction, possibly resulting in bodily injury. Under NO circumstances should chlorinated solvents be used with the "SG2" pressure cup with agitator (80-351). With the standard "SG2" pressure cup, use chlorinated solvents only when using plastic liner (80-355).

### ⚠ CAUTION

Do not exceed 100 PSIG input air pressure into the cup. Excessive pressure could damage components.

### NOTE

Before refilling canister with paint, shut off air supply to the cup and release pressure from canister by rotating pressure relief knob counterclockwise.

## TYPICAL INSTALLATION

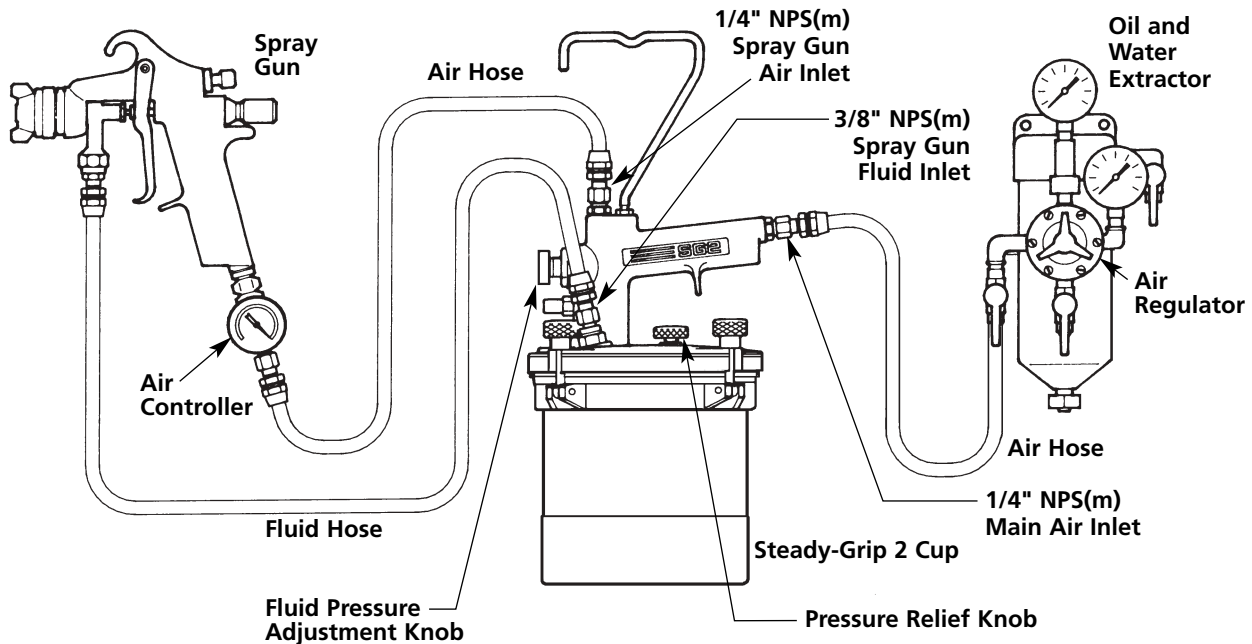

---

## SPRAY TECHNIQUE

The first requirement for a good resultant finish is the proper handling of the gun. The gun should be held perpendicular to the surface being covered and moved parallel with it. The stroke should be started before the trigger is pulled, and the trigger should be released before the stroke is ended.

This gives accurate control of the gun and material. The distance between the gun and surface should be 6 to 10 inches depending on material and atomizing pressure. The material deposited should always be even and wet. Lap each stroke over the preceding stroke to obtain a uniform finish.

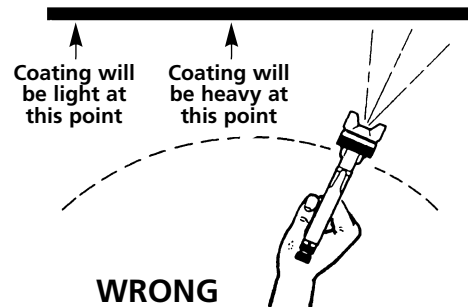
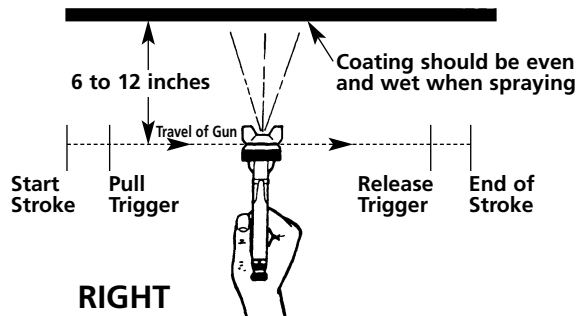

---

## Binks STEADI-GRIP 2 OUTFIT

---

### HVLP GUN OUTFITS

---

#### 98-1198\* OUTFIT

**MACH 1SL Gun with Standard cup**  
consisting of:

- ▶ 80-350 STEADI-GRIP 2 QT. PRESSURE POT (Std.).
- ▶ 73-125 AIR FLOW CONTROLLER, Mounted on gun inlet.
- ▶ MACH 1SL HANDGUN with 92 FLUID NOZZLE by 94P AIRCAP ASSEMBLY.
- ▶ 71-1201 AIR HOSE, 3/8" x 5' Long.
- ▶ 71-3380 FLUID HOSE, 1/4" x 5' Long.

\*Available from Industrial Finishing distributors only.

**MODEL 80-350 PRESSURE CUP (Standard)**

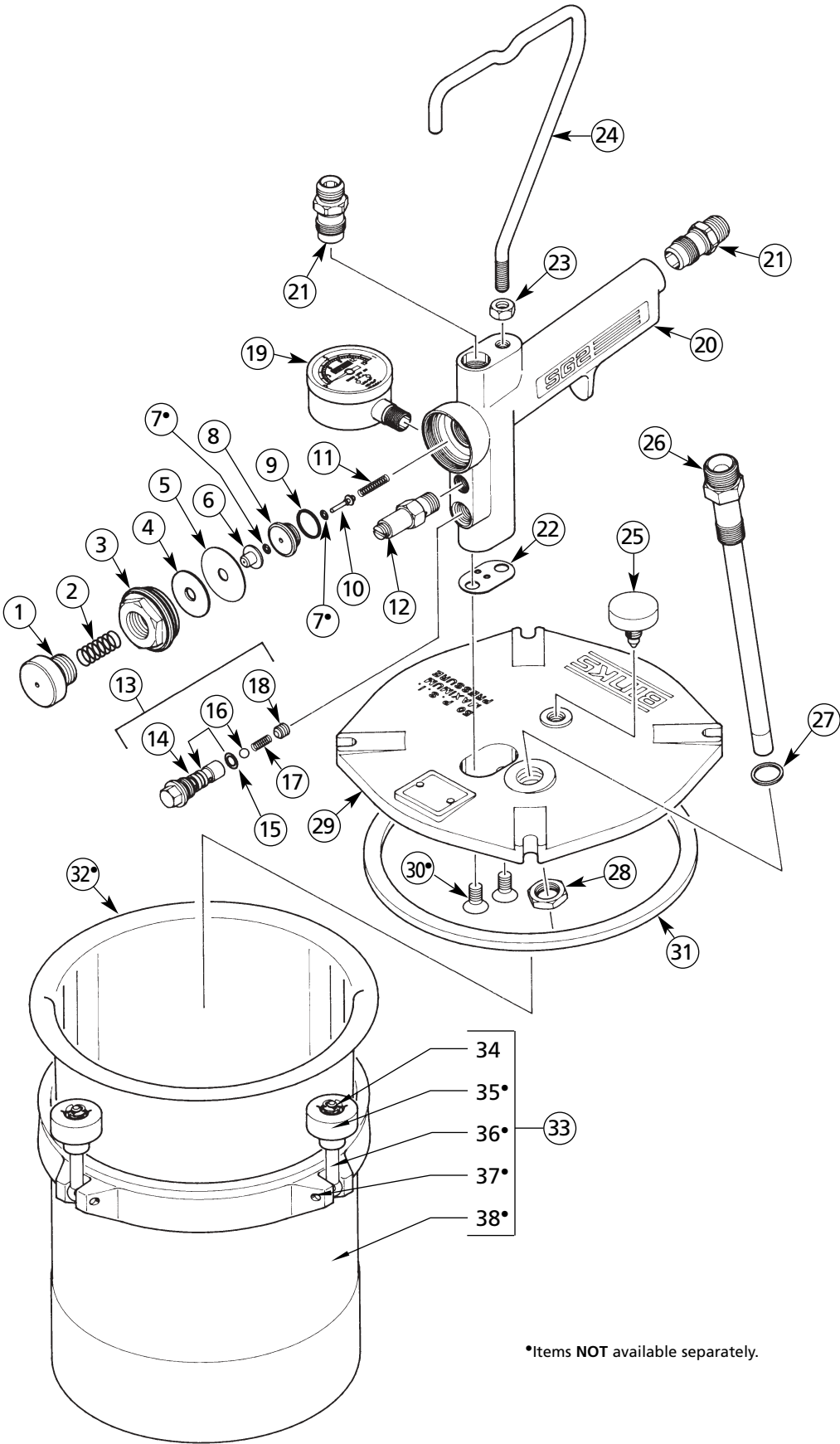

•Items NOT available separately.

## MODEL 80-350 PRESSURE CUP (Standard)

### PARTS LIST

(When ordering, please specify Part No.)

ITEM NO.	PART NO.	DESCRIPTION	QTY.	ITEM NO.	PART NO.	DESCRIPTION	QTY.
1	85-46	SPRING CAP .....	1	25	80-372	VENT KNOB .....	1
2	85-257▲	SPRING .....	1	26	80-385	FLUID TUBE ASSEMBLY .....	1
3	85-184	CAP .....	1	27	80-388▲	FLUID TUBE SEAL.....	1
4	85-267▲	WASHER .....	1	28	80-389★	FLUID TUBE NUT .....	1
5	85-183-5▲○	DIAPHRAGM .....	1	29	80-370	CANISTER LID Standard .....	1
6	85-262	DIAPHRAGM RETAINER.....	1	30	20-6582●	SCREW 1/4-20 X 5/8 Flat Head Socket .....	2
7	20-6683▲●	O-RING 2-003 EPR .....	2	31	80-392 ▲	LID GASKET (E.P.D.M.).....	1
8	85-181	SEAT .....	1	32	80-355○	DISPOSABLE CAN LINER See 80-356 below .....	1
9	85-266▲	SEAL .....	1	33	80-375	2 QT. CANISTER ASSEMBLY..	1
10	85-259	VALVE .....	1	34	80-382■†	RETAINER RING .....	4
11	54-1637▲	SPRING .....	1	35	80-380■●†	KNOB .....	4
12	85-84▲	POP VALVE (Set at 15 psig) .....	1	36	80-381■●†	SWIVEL .....	4
13	80-360▲	CHECK VALVE ASSEMBLY ....	1	37	20-4870■●†PIN	.....	4
14	80-361★	CHECK VALVE BODY .....	1	38	†	CANISTER .....	1
15	20-3619★	O-RING .....	1				
16	20-2183★	BALL 3/16 Dia. ....	1				
17	80-362★	CHECK VALVE SPRING .....	1				
18	20-6161★	SET SCREW 1/4-28 X 1/4 Headless Hex .....	1				
19	GA-313	GAUGE (0-15 psig).....	1				
20	80-365	STEADI-GRIP HANDLE .....	1				
21	54-768	AIR CONNECTION 1/4 NPS (m) 2					
22	80-373▲★	HANDLE GASKET .....	1				
23	80-367★	AUXILIARY HANDLE NUT ....	1				
24	80-364	AUXILIARY HANDLE .....	1				

- ▲ Includes 80-353 Repair Kit.
- Available only as a quantity pack.
- Items **NOT** available separately.
- Indicates parts are included in Spare Parts Kit No. 80-390★ (1 each).
- † Indicates parts are included in 80-375 Assembly (33).
- ★ Available from Industrial Finishing distributors only.

**NOTE**

To convert to High Pressure Kit (0-40 psig), see page 8.

### ACCESSORIES

(Not furnished. Please order separately)

PART NO.	DESCRIPTION	QTY.
80-356	CANISTER LINER QUANTITY PACK .....	12/pk.
80-404★	AGITATOR CUP CONVERSION KIT .....	1
73-125	AIR CONTROLLER (for atomizing air) .....	1
80-352	HIGH FLUID PRESSURE CONVERSION KIT (0-40psig) .....	1
80-353	PRESSURE CUP REPAIR KIT .....	1
80-354★	AGITATOR REPAIR KIT .....	1
80-390★	KNOB REPLACEMENT KIT.....	1

### 80-353 PRESSURE CUP REPAIR KIT

(Models 80-350, 80-351  
Steady-Grip SG-2 Pressure Cups)

PART NO.	DESCRIPTION	QTY.
85-257★	SPRING .....	1
85-183-5○	DIAPHRAGM .....	1
20-6683●	O-RING 2-003 EPR .....	2
85-266★	SEAL .....	1
54-1637★	SPRING .....	1
85-84	POP VALVE 15psi .....	1
80-360	CHECK VALVE ASSEMBLY .....	1
80-373★	HANDLE GASKET .....	1
80-388	FLUID TUBE SEAL.....	1
80-392	LID GASKET (E.P.D.M.) .....	1

- ★ Available from Industrial Finishing distributors only.
- Item **NOT** available separately.
- Available only as a quantity pack.

# Model 80-351 PRESSURE CUP WITH AGITATOR<sup>▲</sup>

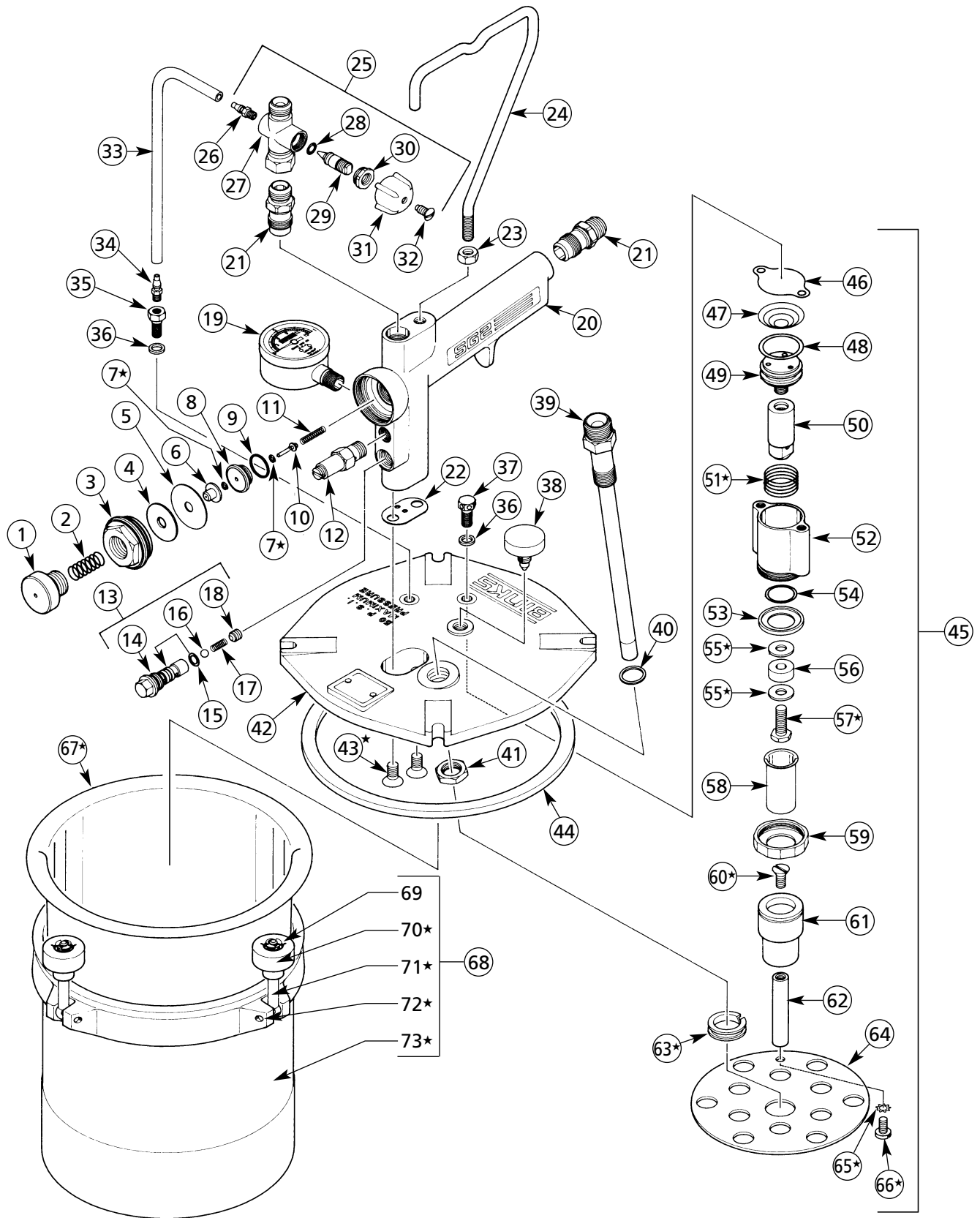

★Items NOT available separately.

# Model 80-351 PRESSURE CUP WITH AGITATOR<sup>▲</sup>

## PARTS LIST

(When ordering, please specify Part No.)

ITEM NO.	PART NO.	DESCRIPTION	QTY.	ITEM NO.	PART NO.	DESCRIPTION	QTY.
1	85-46	SPRING CAP	1	40	80-388▼	FLUID TUBE SEAL	1
2	85-257▼	SPRING	1	41	80-389	FLUID TUBE NUT	1
3	85-184	CAP	1	42	80-369	CANISTER LID Agitator	1
4	85-267▼	WASHER	1	43	20-6582★	SCREW 1/4-20 x 5/8" Flat Hd.Socket	2
5	85-183-5▼○	DIAPHRAGM	1	44	80-392▼	LID GASKET (E.P.D.M.)	1
6	85-262	DIAPHRAGM RETAINER	1	45	80-405	STEADI-GRIP AGITATOR ASSEMBLY..	1
7	20-6683▼★	O-RING 2-003 EPR	2	46	82-727●	CYLINDER GASKET	1
8	85-181	SEAT	1	47	82-720●	CONICAL SPRING	1
9	85-266▼	SEAL	1	48	20-5845●	O-RING	1
10	85-259	VALVE	1	49	82-714●	PISTON ASSEMBLY	1
11	54-1637▼	SPRING	1	50	82-779	PISTON ROD	1
12	85-84▼	POP VALVE (Set at 15 psig)	1	51	82-721●★	COMPRESSION SPRING	1
13	80-360▼	CHECK VALVE ASSEMBLY	1	52	82-711	CYLINDER ASSEMBLY	1
14	80-361	CHECK VALVE BODY	1	53	20-3753●	O-RING	1
15	20-3619	O-RING	1	54	82-776●	CAN SEAL	1
16	20-2183	BALL, 3/16 Dia.	1	55	82-777★	INNER RING	2
17	80-362	CHECK VALVE SPRING	1	56	82-753	INNER MAGNET	1
18	20-6161	SET SCREW 1/4-28 x 1/4" Headless Hex	1	57	20-6022★	SCREW 1/4-28 x 3/4" Hex Hd.	1
19	GA-313	GAUGE (0-15 psig)	1	58	82-775●	CAN	1
20	80-365	STEADI-GRIP HANDLE	1	59	82-778	CAN RETAINER	1
21	54-768	AIR CONNECTION	2	60	20-6023★	SCREW 12-24 X 1/2" Flat Hd.	1
22	80-373▼	HANDLE GASKET	1	61	82-770	OUTER MAGNET ASSEMBLY	1
23	80-367	AUXILIARY HANDLE NUT	1	62	80-406	STEADI-GRIP AGITATOR POST	1
24	80-364	AUXILIARY HANDLE	1	63	20-6583●★	GROMMET	1
25	82-740	AIR CONTROL VALVE ASSEMBLY ..	1	64	80-407	STEADI-GRIP AGITATOR PLATE ..	1
26	81-307 ◆	BARBED CONNECTOR	1	65	20-2530★	#10 EXTERNAL STAR WASHER	1
27	82-745 ◆	VALVE BODY ASSEMBLY	1	66	20-5832★	SCREW 10-32 X 3/8" Pan Hd.	1
28	20-3236 ◆●	O-RING	1	67	80-355○★	DISPOSABLE CAN LINER See 80-356 below	1
29	82-747 ◆	STEM	1	68	80-375	2 QT. CANISTER ASSEMBLY	1
30	73-44 ◆	NUT	1	69	80-382■†	RETAINER RING	4
31	73-46 ◆	CAP	1	70	80-380■★†	KNOB	4
32	20-2606 ◆	SCREW 8-32 x 3/8" Oval Hd.	1	71	80-381■★†	SWIVEL	4
33	54-3929	TUBE 6-1/2" Nylon	1	72	20-4870■★†	PIN	4
34	81-307	BARBED CONNECTOR	1	73	†	CANISTER	1
35	82-728	INLET FITTING	1				
36	82-730●	GASKET	2				
37	82-729	EXHAUST FITTING	1				
38	80-372	VENT KNOB	1				
39	80-385	FLUID TUBE ASSEMBLY	1				

- ▼ Part of 80-353 Pressure Cup Repair Kit.
- Part of 80-354 Agitator Repair Kit.
- ◆ Part of Air Control Valve Assembly, Item 25.
- † Indicates parts are included in 80-375 Assembly. Item #68.
- Indicates parts are included in Spare Parts Kit No. 80-390 (1 each).
- ★ Items NOT available separately. ○ Available only as quantity pack.

### ACCESSORIES

(Not furnished. Please order separately.)

PART NO.	DESCRIPTION	QTY.
80-356	CANNISTER LINER QUANTITY PACK	12/pk.
80-404▲	AGITATOR CUP CONVERSION KIT	1
73-125	AIR CONTROLLER (For atomizing air)	1
80-352▲	HIGH FLUID PRESSURE CONVERSION KIT (0-40 psig)	1
80-353▲	PRESSURE CUP REPAIR KIT	1
80-354▲	AGITATOR REPAIR KIT	1
80-390▲	KNOB REPLACEMENT KIT	1

### AGITATOR REPAIR KIT 80-354<sup>▲</sup>

(Model 80-351 Steadi-Grip SG-2 Pressure Cup with Agitator)

PART NO.	DESCRIPTION	QTY.
20-3236-5○	O-RING 2-008	1
82-730	GASKET	2
82-727	CYLINDER GASKET	1
82-720	CONICAL SPRING	1
20-5845	O-RING 2-118 VITON	1
82-721★	SPRING	1
20-3753	O-RING 2-016 VITON	1
82-776	CAN SEAL	1
82-775	CAN	1
20-6583★	GROMMET	1
82-714	PISTON ASSEMBLY	1

- ▲ Available from Industrial Finishing distributors only.
- Available only as quantity pack.
- ★ Items NOT available separately.

# MODEL 80-352 HIGH PRESSURE RETRO-FIT CONVERSION KIT

## CONVERSION INSTRUCTIONS

Before converting to high pressure kit, depressurize and shut off the entire system before installing the conversion kit. Keep the cup lid in fully clamped position.

### **⚠ WARNING**

Attempting to install the conversion kit while the system is pressurized could result in damage to components or bodily injury.

To convert to high pressure (0-40 psig) remove spring cap (1) and replace spring (2) with an 85-80 spring.

Then, replace the standard GA-313 gauge (0-15 psig) with an 85-70 (0-60 psig) gauge (3).

Pressurize the cup slowly with air by turning spring cap (1) clockwise. With the spring cap screwed all the way in, adjust the pop valve by turning the pop valve adjustment screw (4) clockwise until the pop valve releases air at 40 psi gauge pressure as shown in the illustration below. All items to convert to high pressure are provided in 80-352 kit.

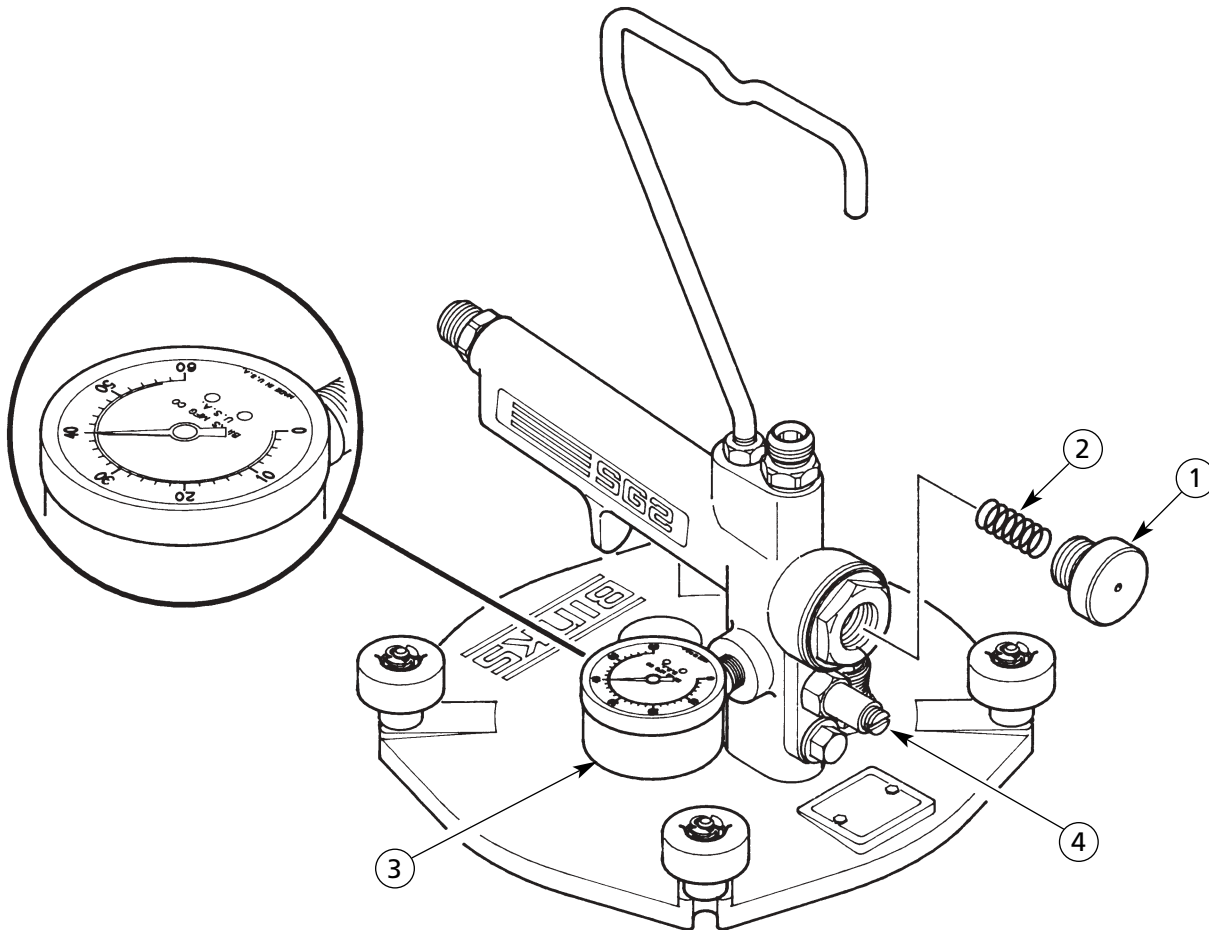

### WARRANTY

This product is covered by Binks' 1 Year Limited Warranty.

**Binks Worldwide Sales and Service Listing: [www.binks.com](http://www.binks.com)**

#### Industrial Finishing

Binks has authorized distributors throughout the world. For technical assistance or the distributor nearest you, see listing below.

##### U.S./Canada Technical Service Office:

195 Internationale Blvd., Glendale Heights, IL 60139  
Toll-Free Telephone: 1-888-992-4657 (U.S.A. and Canada only)  
Toll-Free Fax: 1-888-246-5732

#### Automotive Refinishing

Binks has authorized distributors throughout the world. For equipment, parts and service, check the Yellow Pages under "Automotive Body Shop Equipment and Supplies." For technical assistance, see listing below.

##### U.S./Canada Customer Service Office:

1724 Indian Wood Circle, Suite J-K, Maumee, OH 43537  
Toll-Free Telephone: 1-800-445-3988 (U.S.A. and Canada only)  
Toll-Free Fax: 1-800-445-6643



77-2658R-4 Revisions: (P5) Added footnote to Item No. 4; (P7) Added footnote to Item No. 4, changed quantity of Item No. 7.